

Main Features

- 1-Horizontal centrifugal multistage pump, self priming type.
- 2-Low noise standard motor, with high quality mechanical seal.
- 3-Pump sleeve is stainless steel, impeller and hydraulic stake are thermoplastic, inlet and outlet are cast iron.
- 4-Threaded connection.
- 5-Light weight, high pressure, high efficiency and durability.
- 6-Single phase motor mounted with thermal protection, three phase motor can be based on customer requiremnts to install thermal protector.
- 7-Motor insulation class F, IP55.

Application:

- 1-Convey clean water without abrasive or fiber.
- 2-Water treatment.
- 3-Air conditioning and cooling system.
- 4-high building boosting water supply, garden sprinkler.



Working conditions

- Medium temperatur: +70C
- Ampient temperature: +50C MAX.
- Max, working pressure: 10bar

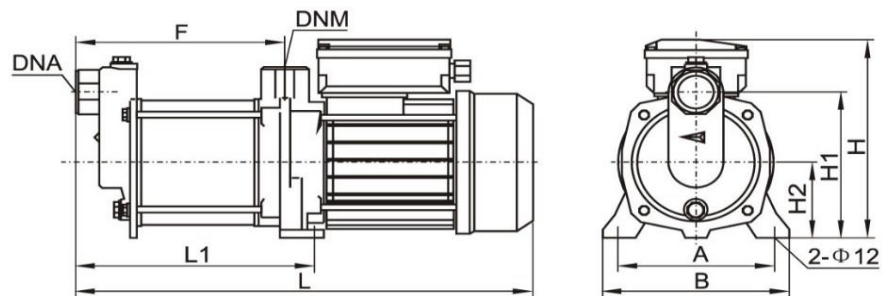

Technical detail

RB Model	Power P2 (kw)	Amps		Rated head m	Rated flow m3/h	Dimenssion (mm)								DNA	DNM	Weight kg		
		220v/50Hz	380/50Hz			A	B	L	L1	L2	H	H1	H2					
RB2-9X2(T)	0.37	2.4	1	18	2	141	170	360	167	142	206	145	75	G1	G1	11		
RB2-9X3(T)	0.55	4.2	1.4	27		141	170	384	191	166	206	145	75			12.5		
RB2-9X4(T)	0.75	5.2	1.8	36		141	170	409	215	190	206	145	75			13.5		
RB2-9X5(T)	1	6.2	2.4	45		141	170	432	239	214	206	145	75			15		
RB2-9X6(T)	1	6.2	2.4	54		141	170	456	263	238	206	145	75			16		
RB4-9X2(T)	0.55	4.2	1.4	18	4	141	170	360	167	142	206	145	75			G1	G1	12.5
RB4-9X3(T)	0.75	5.2	1.8	27		141	170	384	191	166	206	145	75					14
RB4-9X4(T)	1	6.2	2.4	36		141	170	408	215	190	206	145	75					14.5
RB4-9X5(T)	1.5	9.6	3.5	45		121	152	470	245	220	225	155	85					16
RB4-9X6(T)	1.5	9.6	3.5	54		121	152	495	269	244	225	155	85					20

Main Features

- 1-Horizontal centrifugal multistage pump, self priming type.
- 2-Low noise standard motor, with high quality mechanical seal.
- 3-Pump sleeve is stainless steel, impeller and hydraulic stake are thermoplastic, inlet and outlet are cast iron.
- 4-Threaded connection.
- 5-Light weight, high pressure, high efficiency and durability.
- 6-Single phase motor mounted with thermal protection, three phase motor can be based on customer requiremnts to install thermal protector.
- 7-Motor insulation class F, IP55.

Application:

- 1-Convey clean water without abrasive or fiber.
- 2-Water treatment.
- 3-Air conditioning and cooling system.
- 4-high building boosting water supply, garden sprinkler.



Working conditions

- Medium temperatur: +70C
- Ampient temperature: +50C MAX.
- Max, working pressure: 10bar

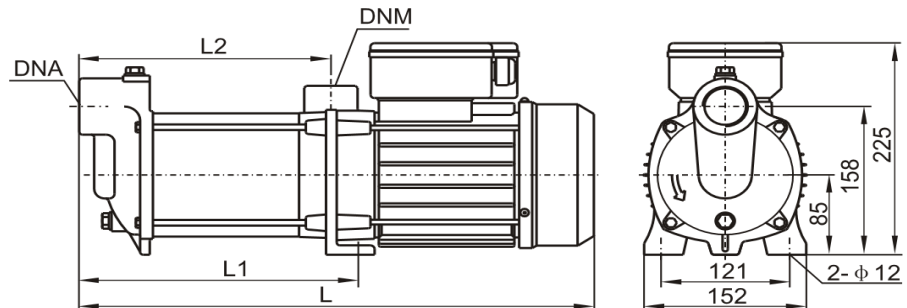

Technical detail

RB Model	Power P2 (kw)	Amps		Rated head m	Rated flow m3/h	Dimension (mm)			DNA	DNM	Weight kg
		220v/50Hz	380/50Hz			L	L1	L2			
RB6-8.5X3(T)	1.1	6.8	2.9	25	4	470	250	226	G1 1/4	G1 1/4	18.5
RB6-8.5X4(T)	1.5	9.6	3.5	34		507	287	263			19
RB6-8.5X5(T)	2.2	14	5.2	42		544	324	300			21.5
RB6-8.5X6(T)	2.2	14	5.2	51		581	361	337			22

Main Features

- 1-Horizontal centrifugal multistage pump, self priming type.
- 2-Low noise standard motor, with high quality mechanical seal.
- 3-Pump sleeve is stainless steel, impeller and hydraulic stake are thermoplastic, inlet and outlet are cast iron.
- 4-Threaded connection.
- 5-Light weight, high pressure, high efficiency and durability.
- 6-Single phase motor mounted with thermal protection, three phase motor can be based on customer requirements to install thermal protector.
- 7-Motor insulation class F, IP55.

Application:

- 1-Convey clean water without abrasive or fiber.
- 2-Water treatment.
- 3-Air conditioning and cooling system.
- 4-high building boosting water supply, garden sprinkler.



Working conditions

Medium temperatur: +70C
 Ampient temperature: +50C MAX.
 Max, working pressure: 10bar

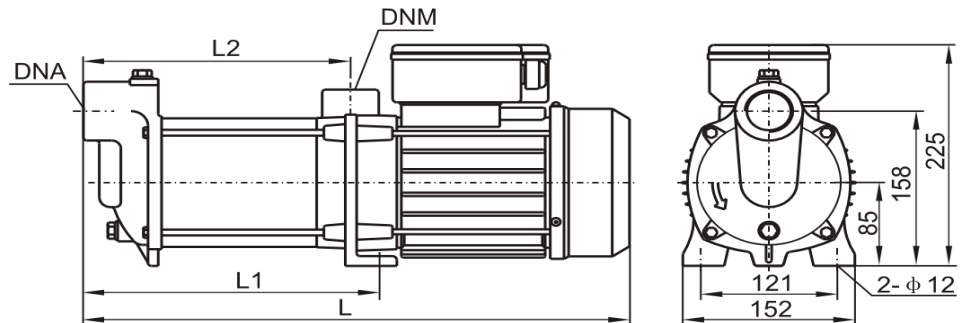

Technical detail

RB Model	Power P2 (kw)	Amps		Rated head m	Rated flow m3/h	Dimension (mm)			DNA	DNM	Weight KG
		220v/50Hz	380/50Hz			L	L1	L2			
RB8-9X2(T)	1.1	6.8	2.9	18	8	436	213	188	G1 1/2	G1 1/4	19
RB8-9X3(T)	1.1	6.8	2.9	27		475	252	227			20
RB8-9X4(T)	1.5	9.6	3.5	36		513	290	265			21
RB8-9X5(T)	2.2	14	5.2	45		552	329	304			22
RB12-8.5X2(T)	1.1	6.8	2.9	17	12	436	213	188			20
RB12-8.5X3(T)	1.5	9.6	3.5	25		475	252	227			22
RB12-8.5X4(T)	2.2	14	5.2	34		513	290	265	23		