

Main Features

- 1-Low noise standard motor, with high quality mechanical seal
- 2-Efficient spiral case pump body design. Compact design.
- 3-Open impeller, convey solide with diameter 19mm.
- 4-Single phase motor mounted with thermal protection, three phase motor can be based on customer requiremnts.
- 5-Many purpose, transfer wide range of liquid.
- 6-Threaded connection.
- 7-Motor insulation class F, IP55.

Application:

- 1-Convey solid suspension in food processing
- 2-Clean vegetable, mear or fish food
- 3-Clean mental components
- 4-Clean bottel, can or glassware etc.
- 5-Circulating and cleaning system for assmebly
- 6-Processing treatment on painting and general dirty liquid
- 7-Convey weak corrosive liquid
- 8-Swimming pool system, drainage system, irrigation



Working conditions

- Medium temperatur: +70C
- Ampient temperature: +50C MAX.
- Max, working pressure: 10bar

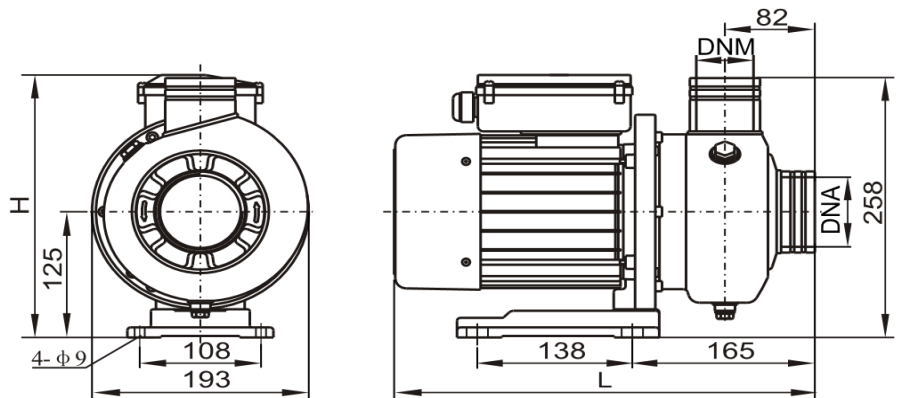

Technical detail

| RDW Model | Power P2 (kw) | Amps | | Rated head m | Rated flow m3/h | Dimenssion (mm) | | | DNA | DNM | Weight kg |
|-----------|---------------|-----------|----------|--------------|-----------------|-----------------|-------|-------|---------|-----|-----------|
| | | 220v/50Hz | 380/50Hz | | | L | H-1ph | H-3ph | | | |
| RDW150(T) | 1.1 | 6.8 | 2.6 | 7.8 | 18 | 378 | 265 | 235 | G2 | G2 | 16 |
| RDW200(T) | 1.5 | 9.6 | 3.5 | 10.5 | | 378 | 265 | 235 | | | 18 |
| RDW300(T) | 2.2 | 14 | 4.5 | 11 | 30 | 415 | 242 | 242 | G 2 1/2 | | 22 |
| RDW400(T) | 3 | | 5.2 | 15 | | 432 | | 242 | | 23 | |